

Chapter 8. Pipelining

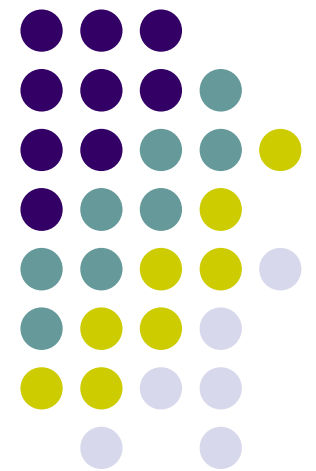

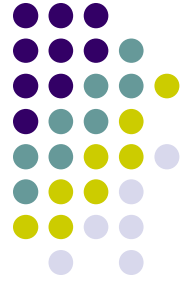

Overview

- Pipelining is widely used in modern processors.
- Pipelining improves system performance in terms of throughput.
- Pipelined organization requires sophisticated compilation techniques.

Basic Concepts

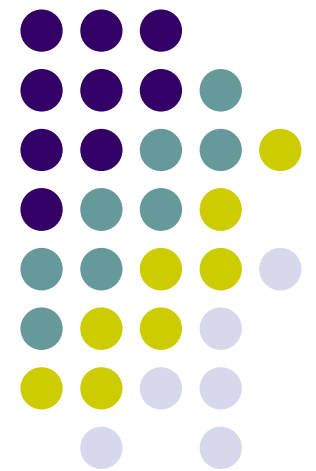

Making the Execution of Programs Faster

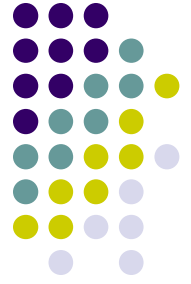

- Use faster circuit technology to build the processor and the main memory.
- Arrange the hardware so that more than one operation can be performed at the same time.
- In the latter way, the number of operations performed per second is increased even though the elapsed time needed to perform any one operation is not changed.

Traditional Pipeline Concept

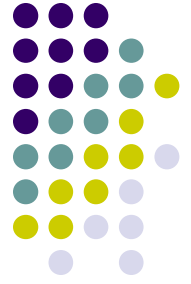

- Laundry Example
- Ann, Brian, Cathy, Dave each have one load of clothes to wash, dry, and fold
- Washer takes 30 minutes
- Dryer takes 40 minutes
- “Folder” takes 20 minutes

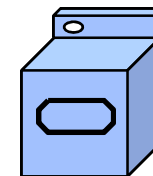
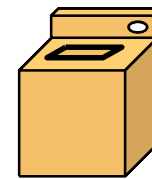
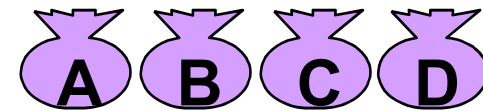

Traditional Pipeline Concept

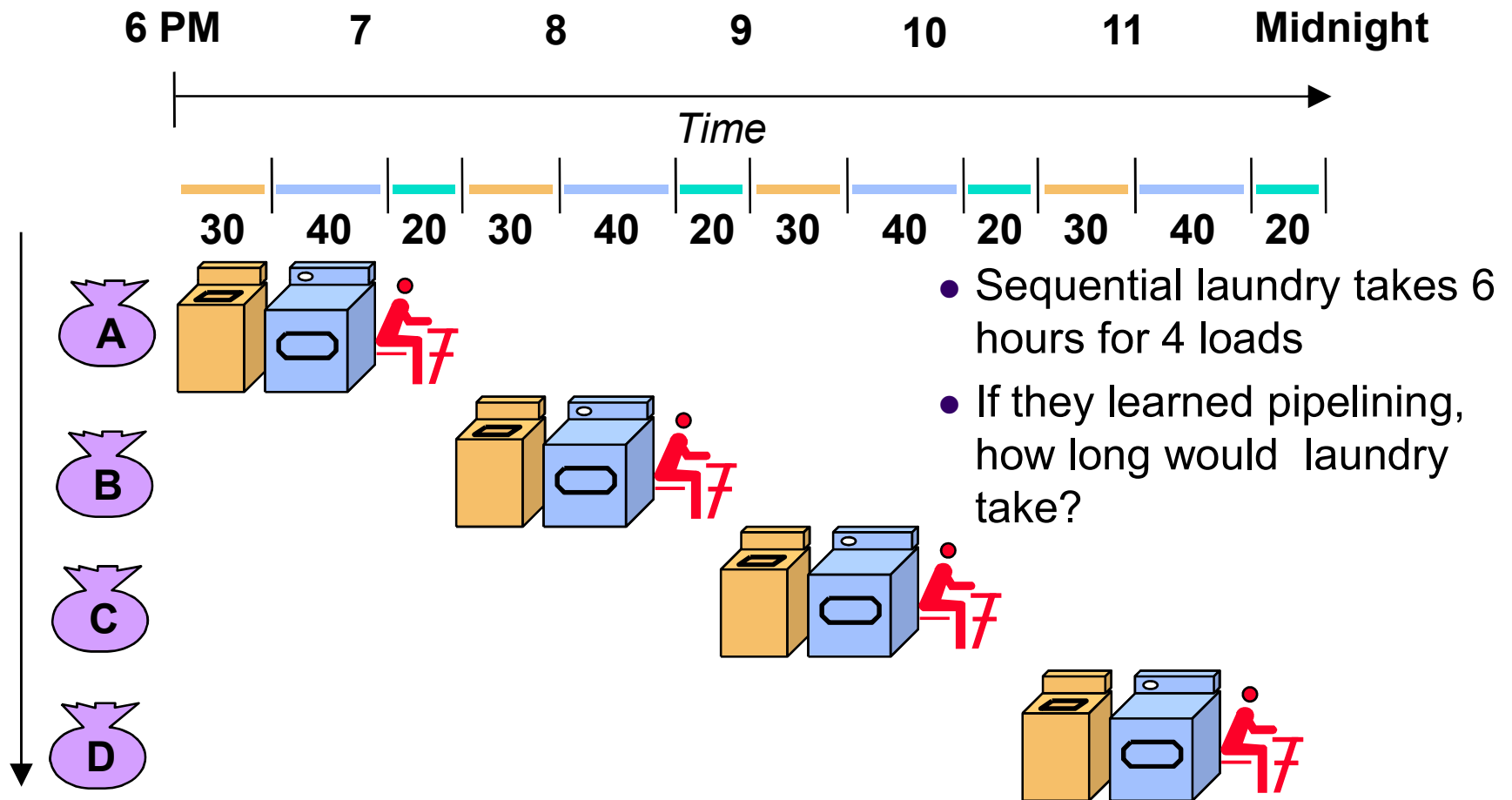
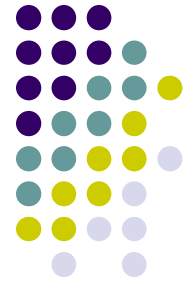

Traditional Pipeline Concept

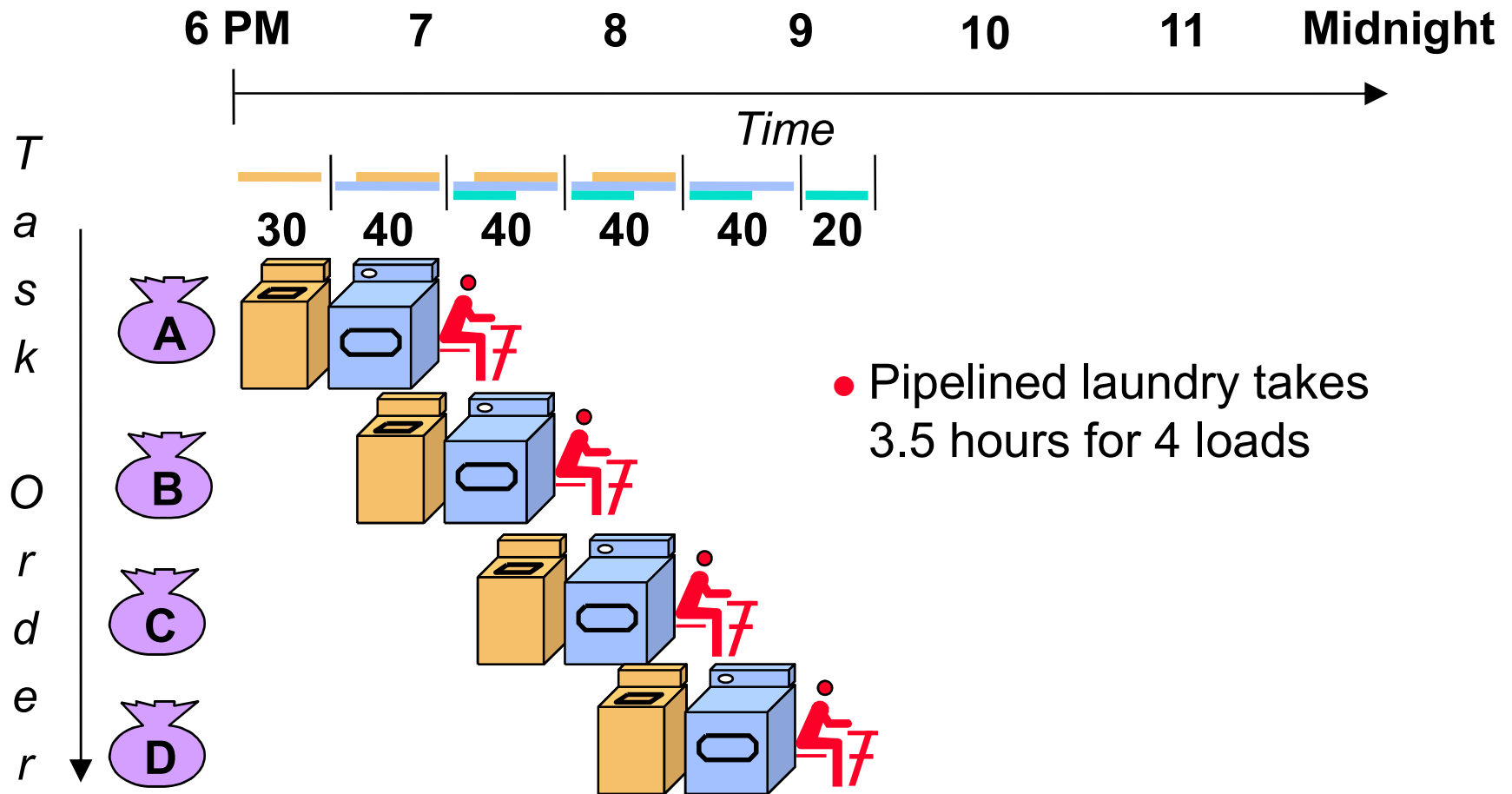
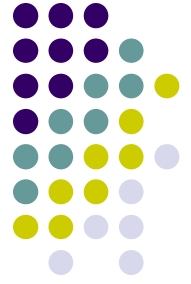



Traditional Pipeline Concept

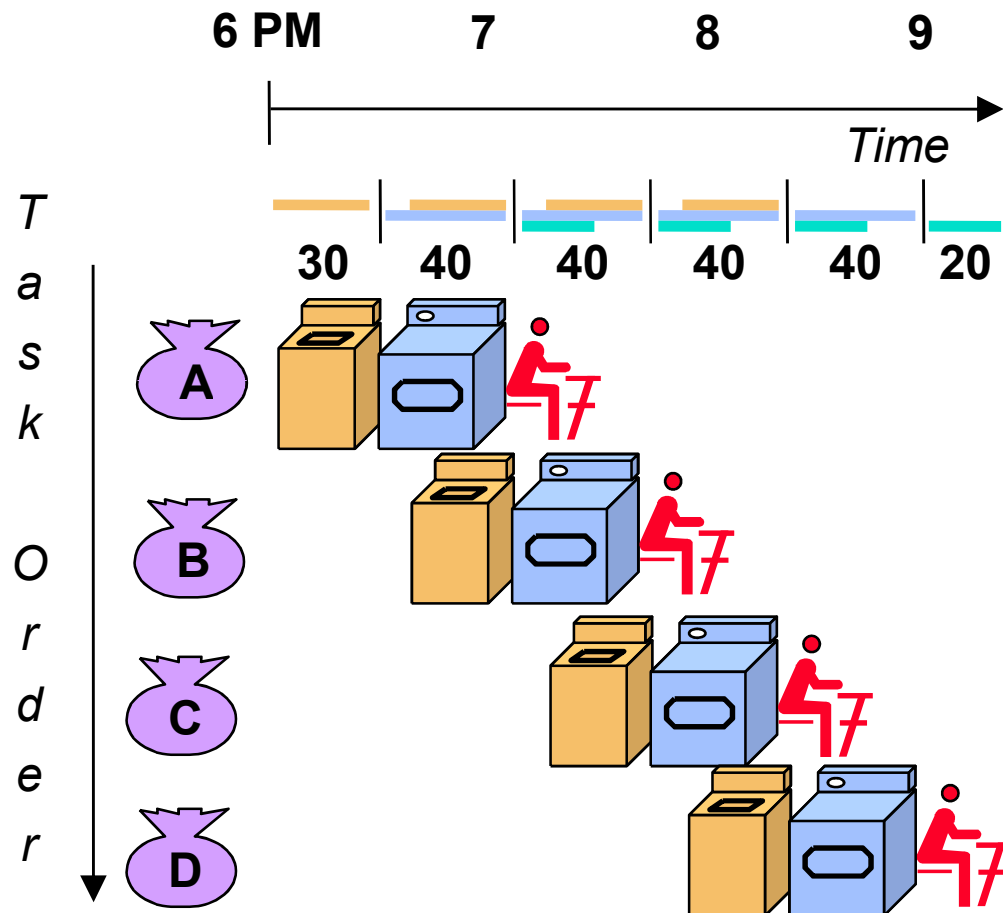

- Pipelining doesn't help latency of single task, it helps throughput of entire workload
- Pipeline rate limited by slowest pipeline stage
- Multiple tasks operating simultaneously using different resources
- Potential speedup = Number pipe stages
- Unbalanced lengths of pipe stages reduces speedup
- Time to "fill" pipeline and time to "drain" it reduces speedup
- Stall for Dependences

Use the Idea of Pipelining in a Computer

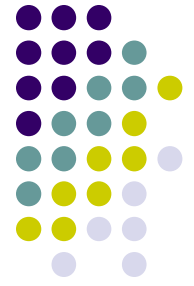

Fetch + Execution

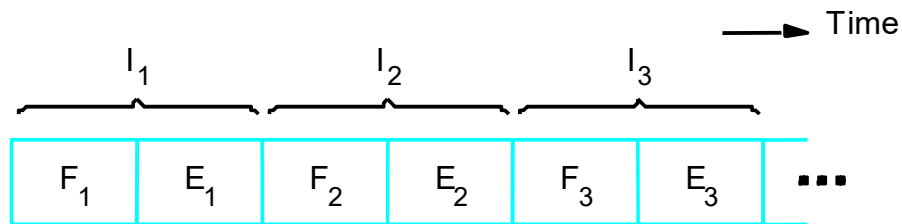

(a) Sequential execution

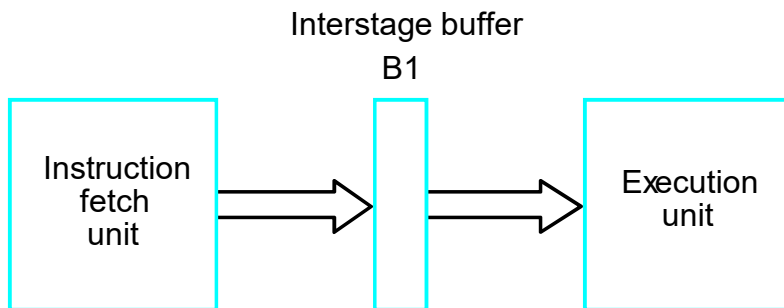

(b) Hardware organization

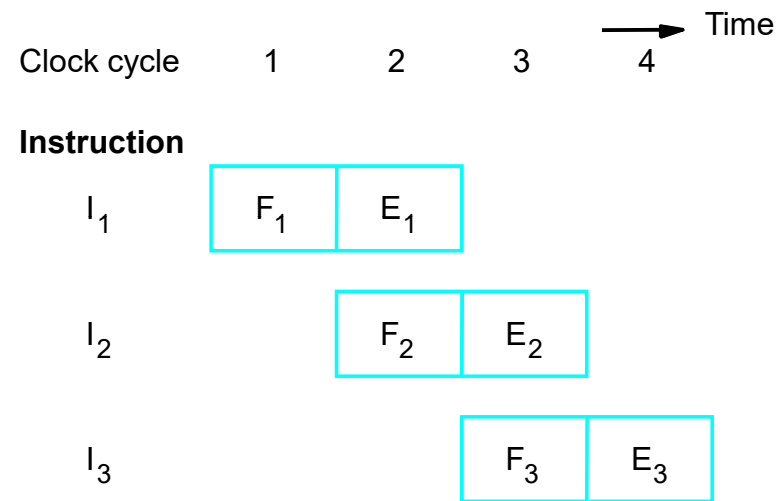

(c) Pipelined execution

Figure 8.1. Basic idea of instruction pipelining.

Use the Idea of Pipelining in a Computer

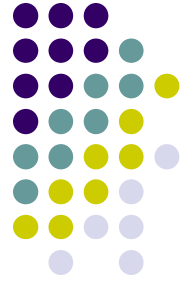

Fetch + Decode
+ Execution + Write

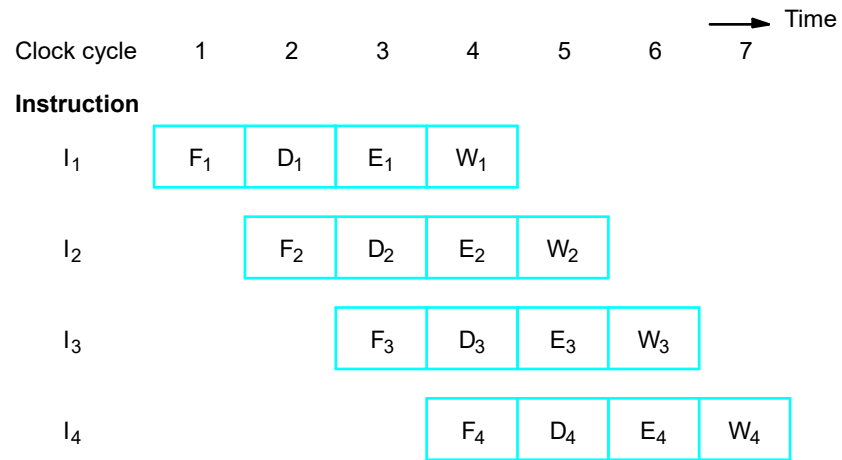

(a) Instruction execution divided into four steps

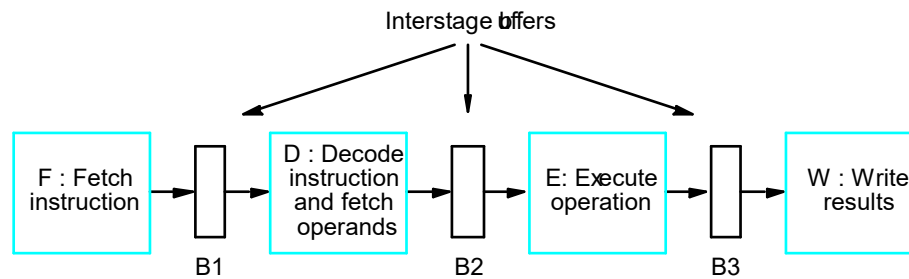

(b) Hardware organization

Textbook page: 457

Figure 8.2. A 4-stage pipeline.

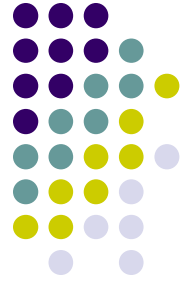

Role of Cache Memory

- Each pipeline stage is expected to complete in one clock cycle.
- The clock period should be long enough to let the slowest pipeline stage to complete.
- Faster stages can only wait for the slowest one to complete.
- Since main memory is very slow compared to the execution, if each instruction needs to be fetched from main memory, pipeline is almost useless.
- Fortunately, we have cache.

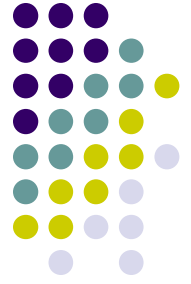

Pipeline Performance

- The potential increase in performance resulting from pipelining is proportional to the number of pipeline stages.
- However, this increase would be achieved only if all pipeline stages require the same time to complete, and there is no interruption throughout program execution.
- Unfortunately, this is not true.

Pipeline Performance

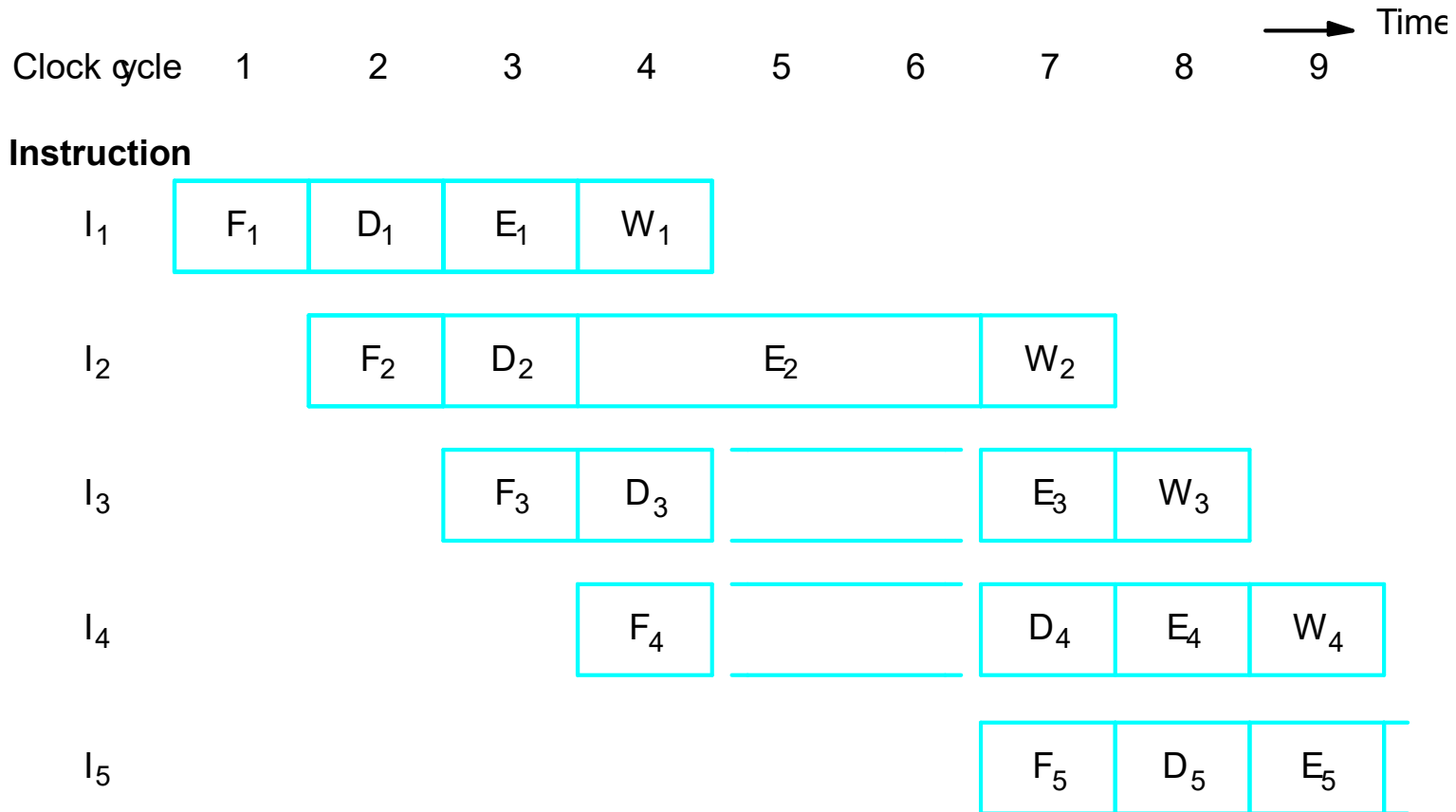
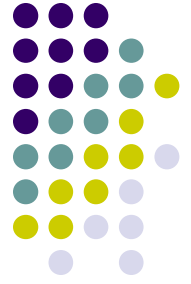
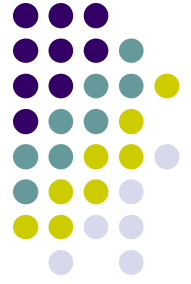

Figure 8.3. Effect of an execution operation taking more than one cycle.

Pipeline Performance



- The previous pipeline is said to have been stalled for two clock cycles.
- Any condition that causes a pipeline to stall is called a hazard.
- Data hazard – any condition in which either the source or the destination operands of an instruction are not available at the time expected in the pipeline. So some operation has to be delayed, and the pipeline stalls.
- Instruction (control) hazard – a delay in the availability of an instruction causes the pipeline to stall.
- Structural hazard – the situation when two instructions require the use of a given hardware resource at the same time.

Pipeline Performance



Instruction hazard

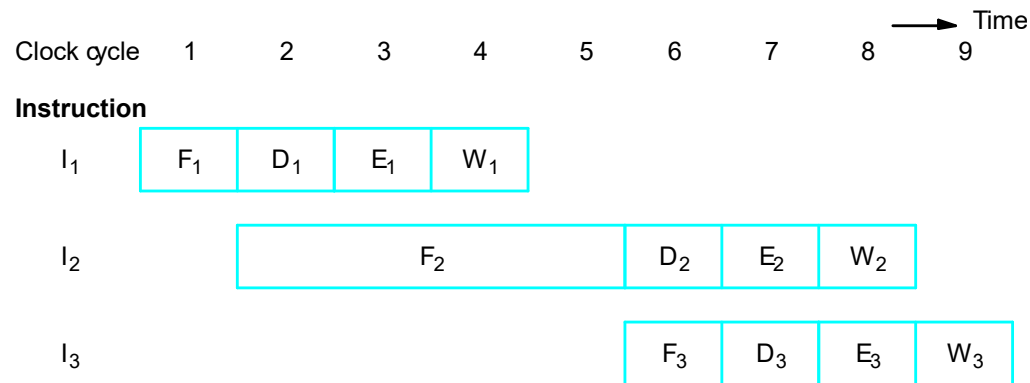

(a) Instruction execution steps in successive clock cycles



Idle periods – stalls (bubbles)

(b) Function performed by each processor stage in successive clock cycles

Figure 8.4. Pipeline stall caused by a cache miss in F2.

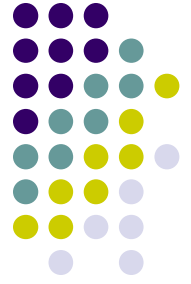

Pipeline Performance

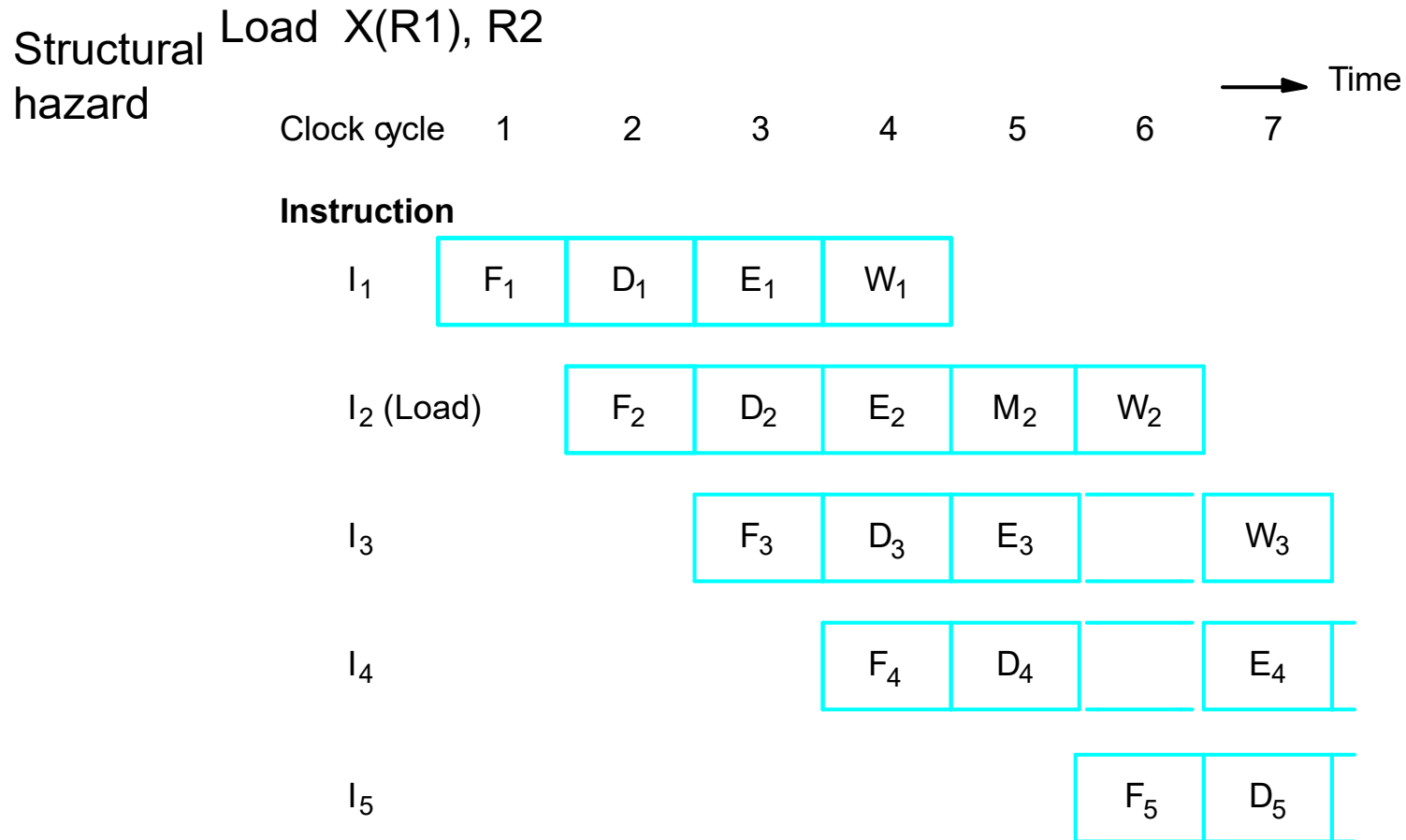
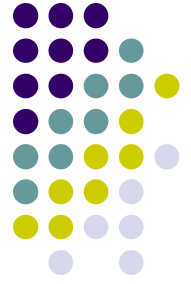

Figure 8.5. Effect of a Load instruction on pipeline timing.



Pipeline Performance

- Again, pipelining does not result in individual instructions being executed faster; rather, it is the throughput that increases.
- Throughput is measured by the rate at which instruction execution is completed.
- Pipeline stall causes degradation in pipeline performance.
- We need to identify all hazards that may cause the pipeline to stall and to find ways to minimize their impact.

Quiz

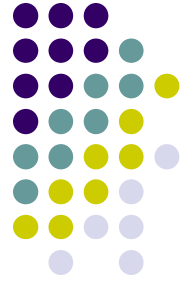

- Four instructions, the I2 takes two clock cycles for execution. Pls draw the figure for 4-stage pipeline, and figure out the total cycles needed for the four instructions to complete.

Data Hazards

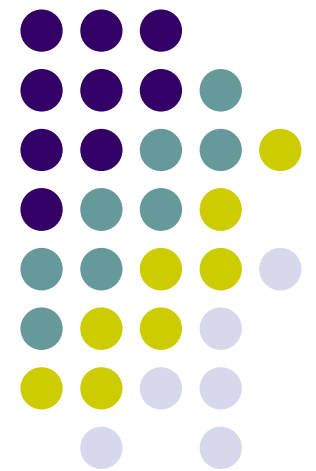

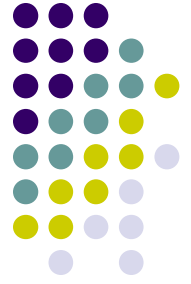

Data Hazards

- We must ensure that the results obtained when instructions are executed in a pipelined processor are identical to those obtained when the same instructions are executed sequentially.
- Hazard occurs
$$A \leftarrow 3 + A$$
$$B \leftarrow 4 \times A$$
- No hazard
$$A \leftarrow 5 \times C$$
$$B \leftarrow 20 + C$$
- When two operations depend on each other, they must be executed sequentially in the correct order.
- Another example:
$$\text{Mul } R2, R3, R4$$
$$\text{Add } R5, R4, R6$$

Data Hazards

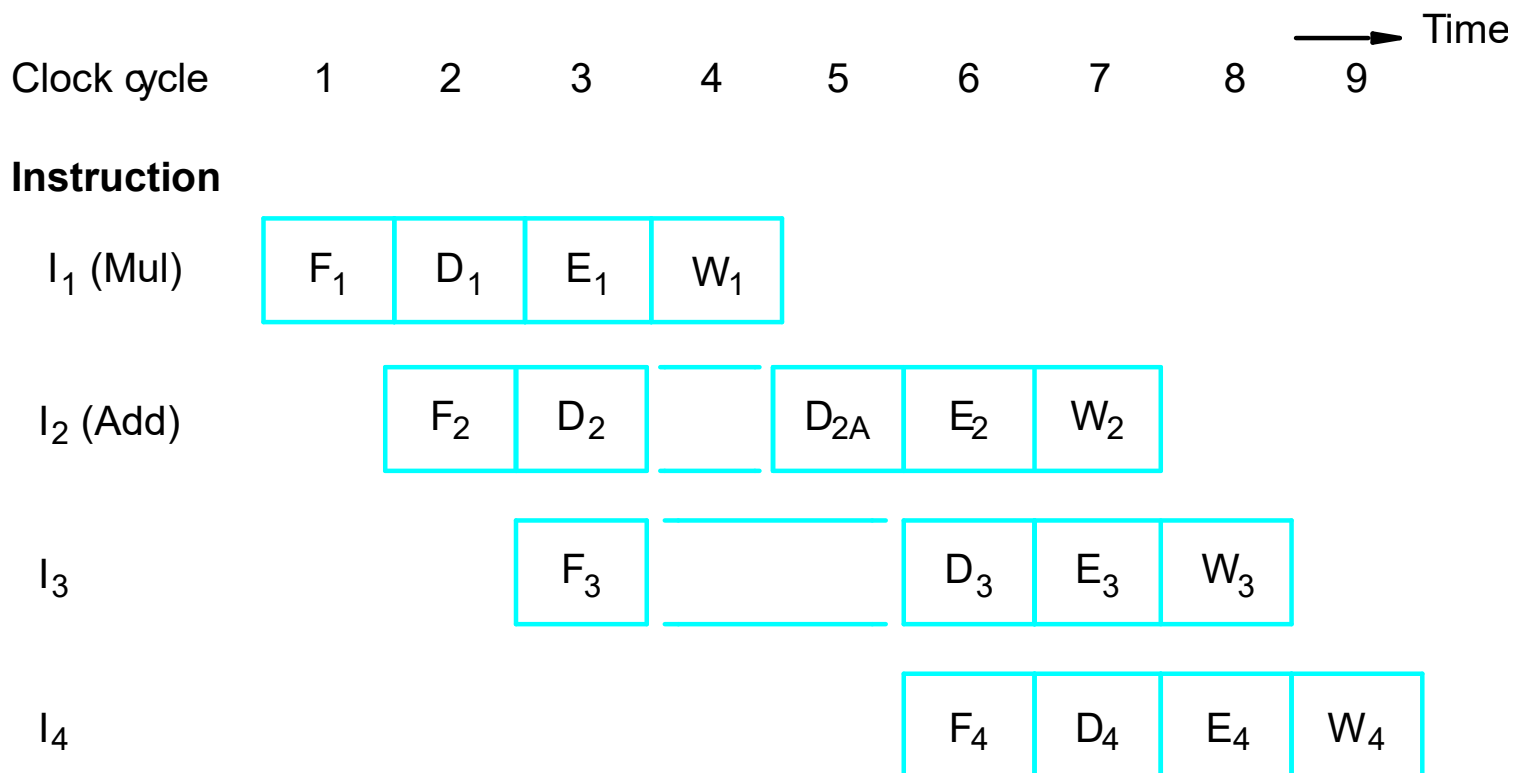
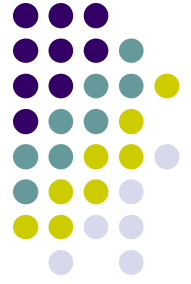
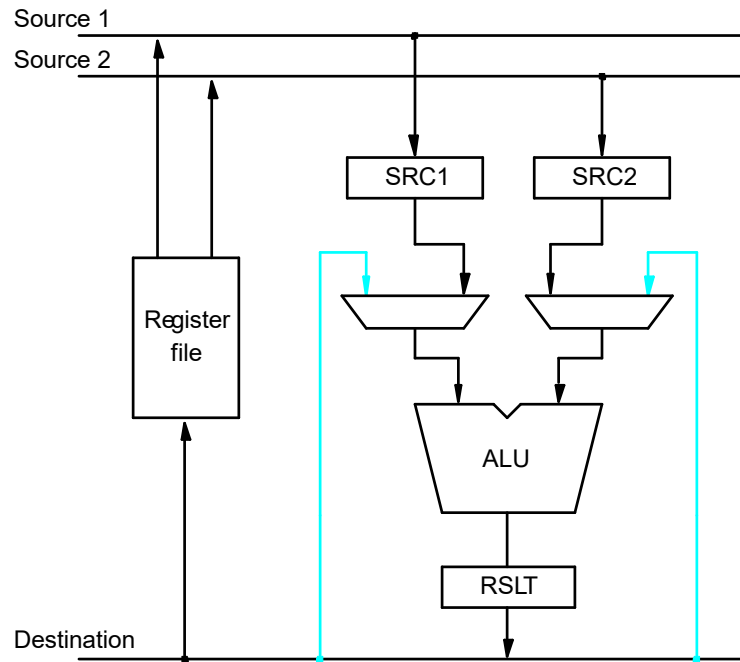

Figure 8.6. Pipeline stalled by data dependency between D_2 and W_1 .

Operand Forwarding



- Instead of from the register file, the second instruction can get data directly from the output of ALU after the previous instruction is completed.
- A special arrangement needs to be made to “forward” the output of ALU to the input of ALU.



(a) Datapath

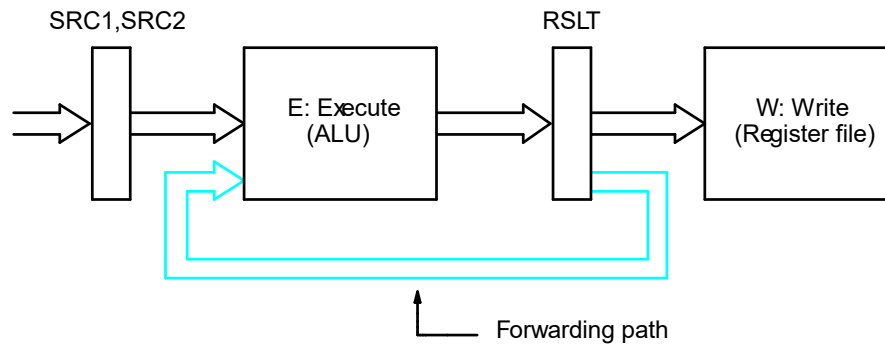

(b) Position of the source and result registers in the processor pipeline

Figure 8.7. Operand forwarding in a pipelined processor

Handling Data Hazards in Software

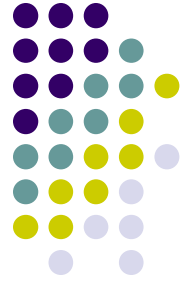

- Let the compiler detect and handle the hazard:

I1: Mul R2, R3, R4

NOP

NOP

I2: Add R5, R4, R6

- The compiler can reorder the instructions to perform some useful work during the NOP slots.

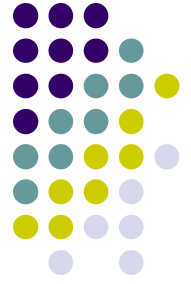

Side Effects

- The previous example is explicit and easily detected.
- Sometimes an instruction changes the contents of a register other than the one named as the destination.
- When a location other than one explicitly named in an instruction as a destination operand is affected, the instruction is said to have a side effect. (Example?)
- Example: conditional code flags:
 - Add R1, R3
 - AddWithCarry R2, R4
- Instructions designed for execution on pipelined hardware should have few side effects.

Instruction Hazards

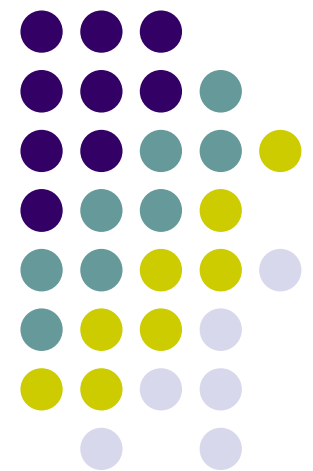

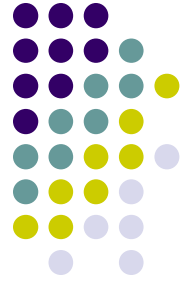

Overview

- Whenever the stream of instructions supplied by the instruction fetch unit is interrupted, the pipeline stalls.
- Cache miss
- Branch

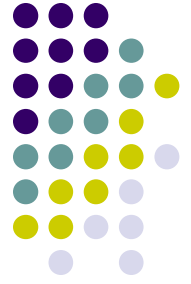

Unconditional Branches

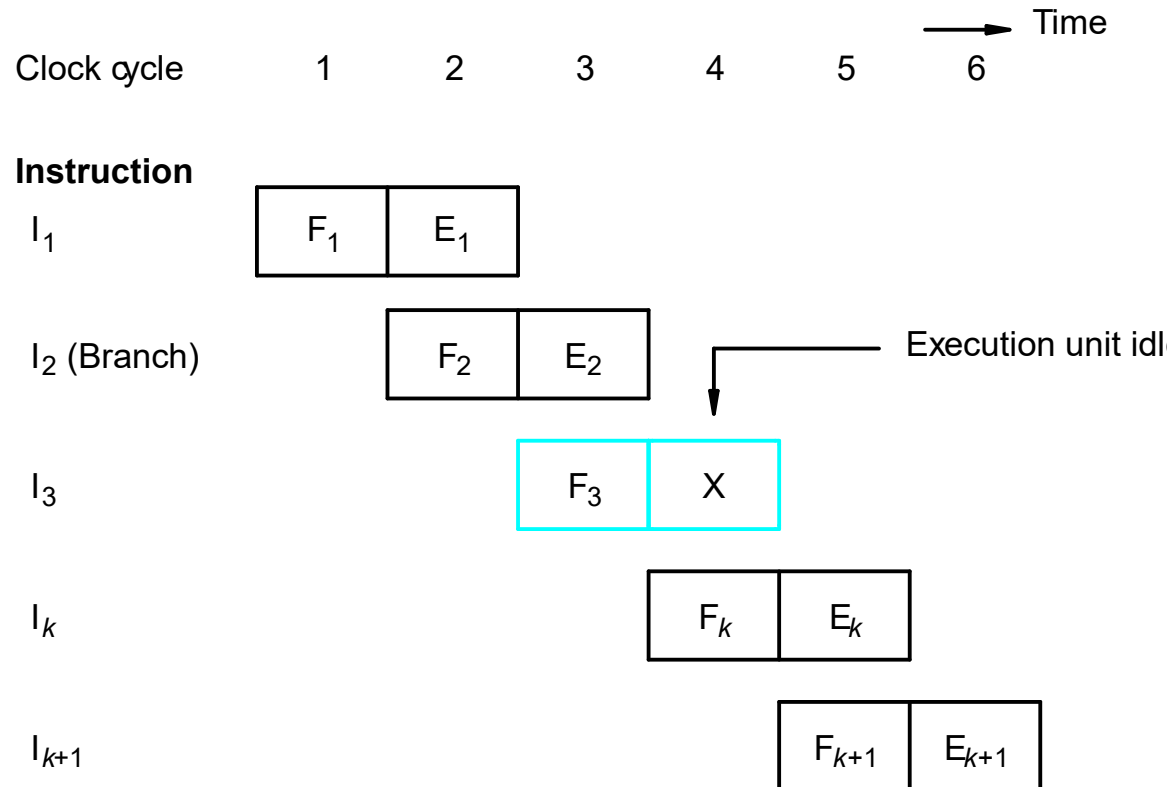
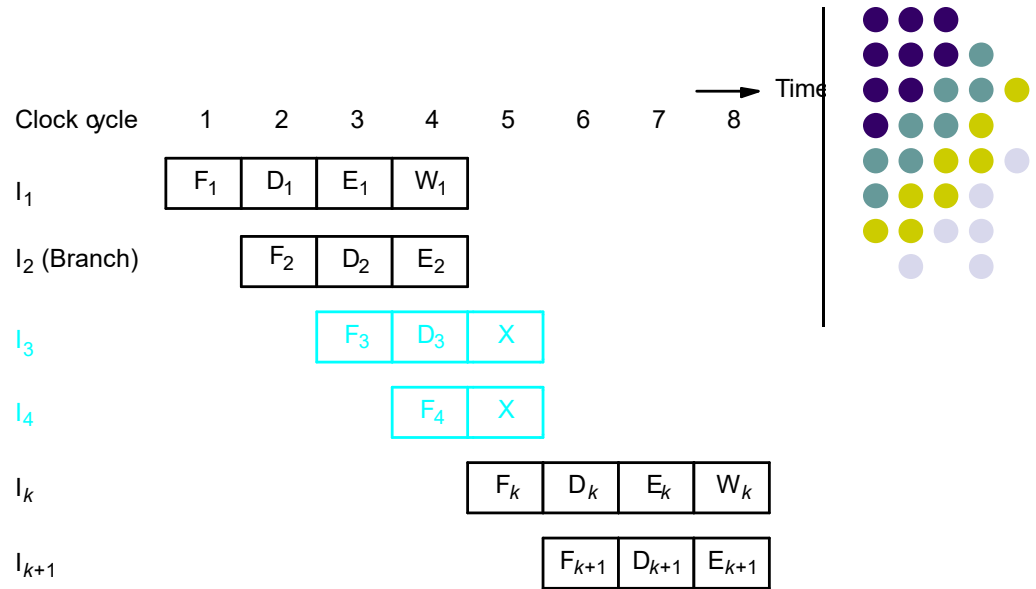

Figure 8.8. An idle cycle caused by a branch instruction.

Branch Timing

- Branch penalty
- Reducing the penalty



(a) Branch address computed in Execute stage

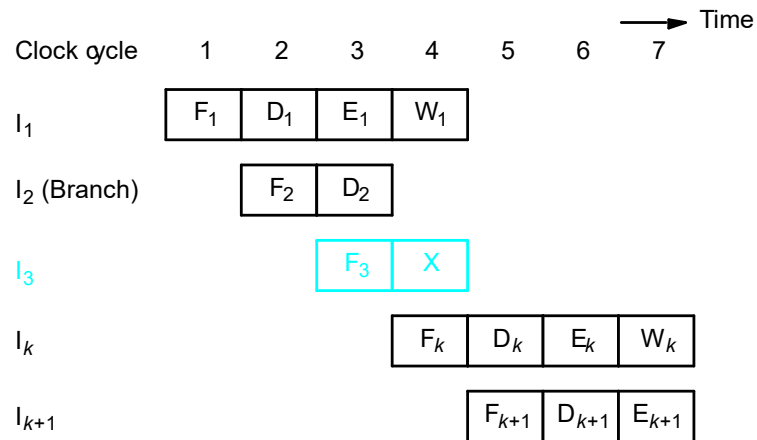

(b) Branch address computed in Decode stage

Figure 8.9. Branch timing.

Instruction Queue and Prefetching

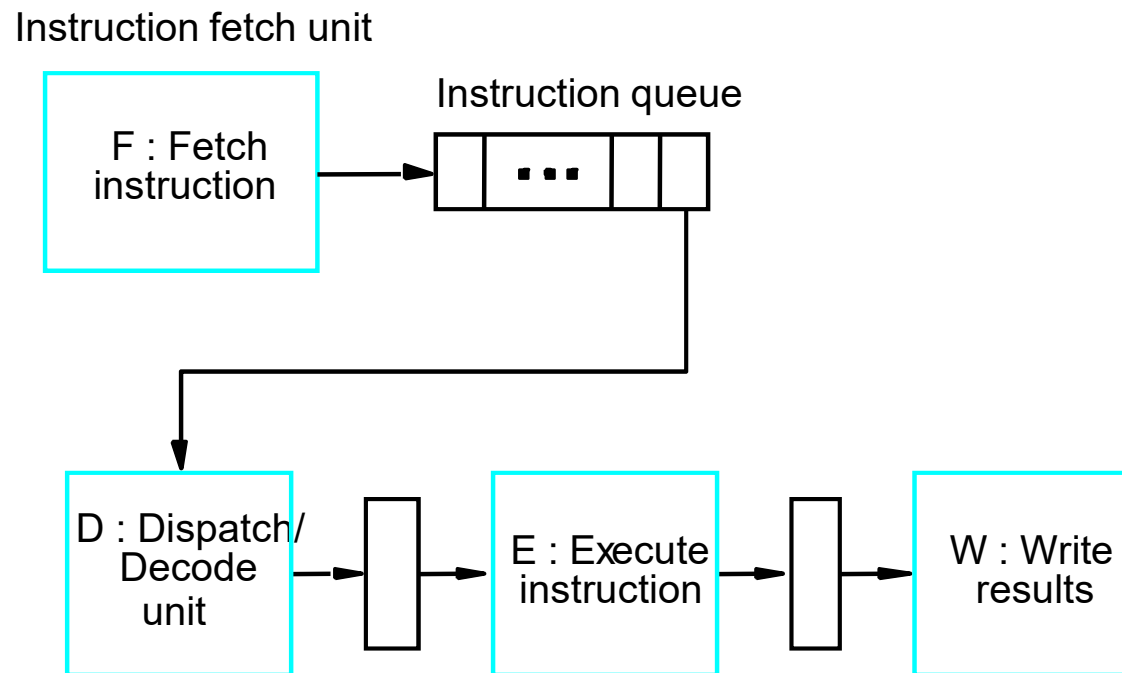
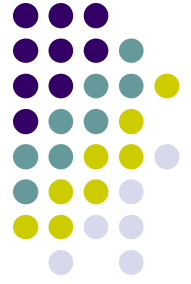
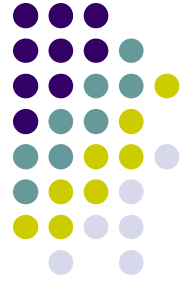
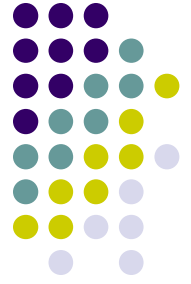

Figure 8.10. Use of an instruction queue in the hardware organization of Figure 8.2b.



Conditional Branches

- A conditional branch instruction introduces the added hazard caused by the dependency of the branch condition on the result of a preceding instruction.
- The decision to branch cannot be made until the execution of that instruction has been completed.
- Branch instructions represent about 20% of the dynamic instruction count of most programs.



Delayed Branch

- The instructions in the delay slots are always fetched. Therefore, we would like to arrange for them to be fully executed whether or not the branch is taken.
- The objective is to place useful instructions in these slots.
- The effectiveness of the delayed branch approach depends on how often it is possible to reorder instructions.

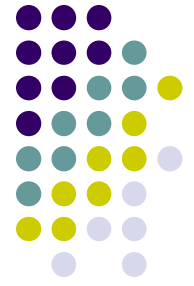

Delayed Branch

LOOP	Shift_left	R1
	Decrement	R2
	Branch=0	LOOP
NEXT	Add	R1,R3

(a) Original program loop

LOOP	Decrement	R2
	Branch=0	LOOP
	Shift_left	R1
NEXT	Add	R1,R3

(b) Reordered instructions

Figure 8.12. Reordering of instructions for a delayed branch.

Delayed Branch

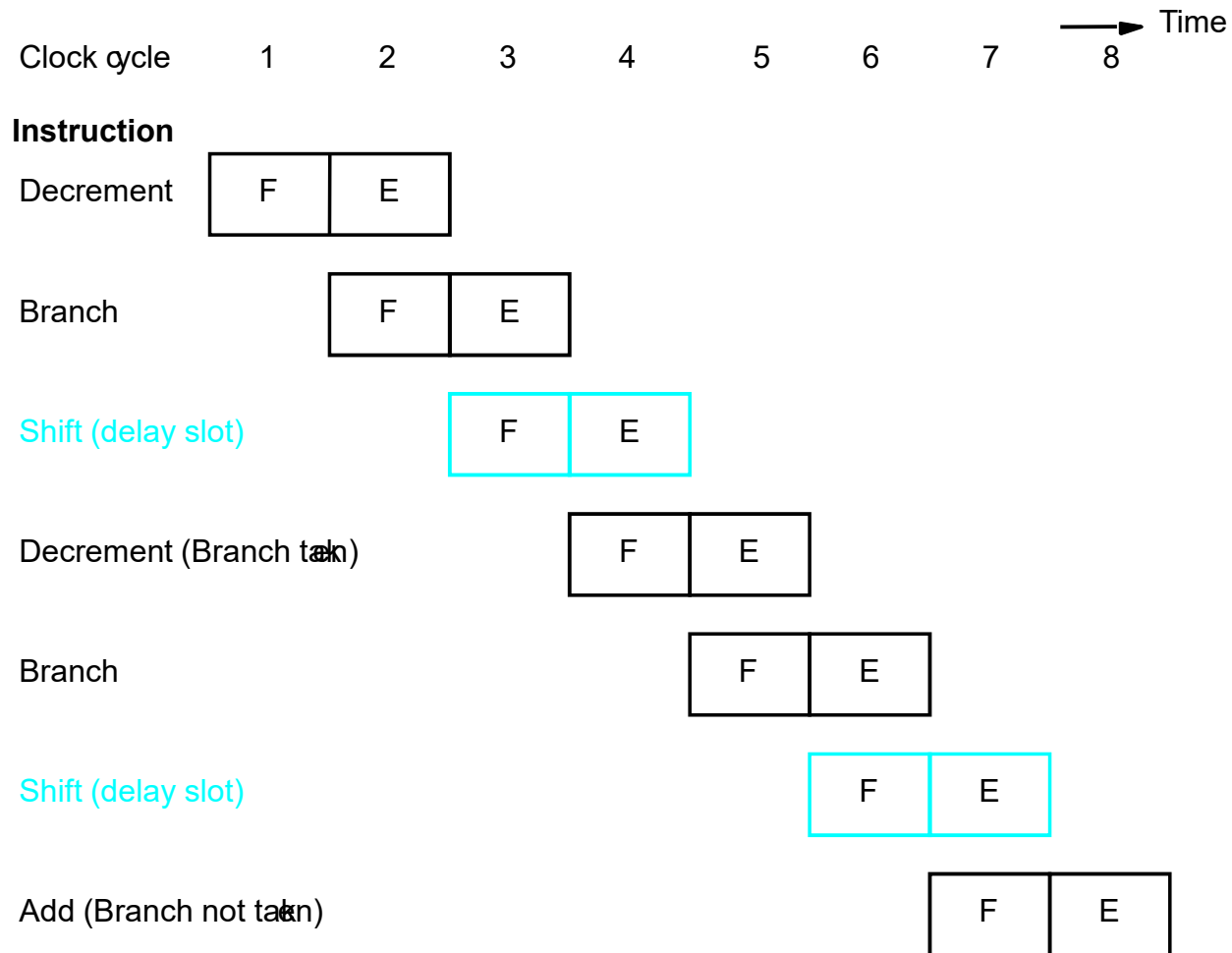
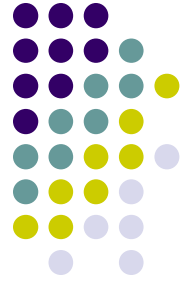

Figure 8.13. Execution timing showing the delay slot being filled during the last two passes through the loop in Figure 8.12.



Branch Prediction

- To predict whether or not a particular branch will be taken.
- Simplest form: assume branch will not take place and continue to fetch instructions in sequential address order.
- Until the branch is evaluated, instruction execution along the predicted path must be done on a speculative basis.
- Speculative execution: instructions are executed before the processor is certain that they are in the correct execution sequence.
- Need to be careful so that no processor registers or memory locations are updated until it is confirmed that these instructions should indeed be executed.



Incorrectly Predicted Branch

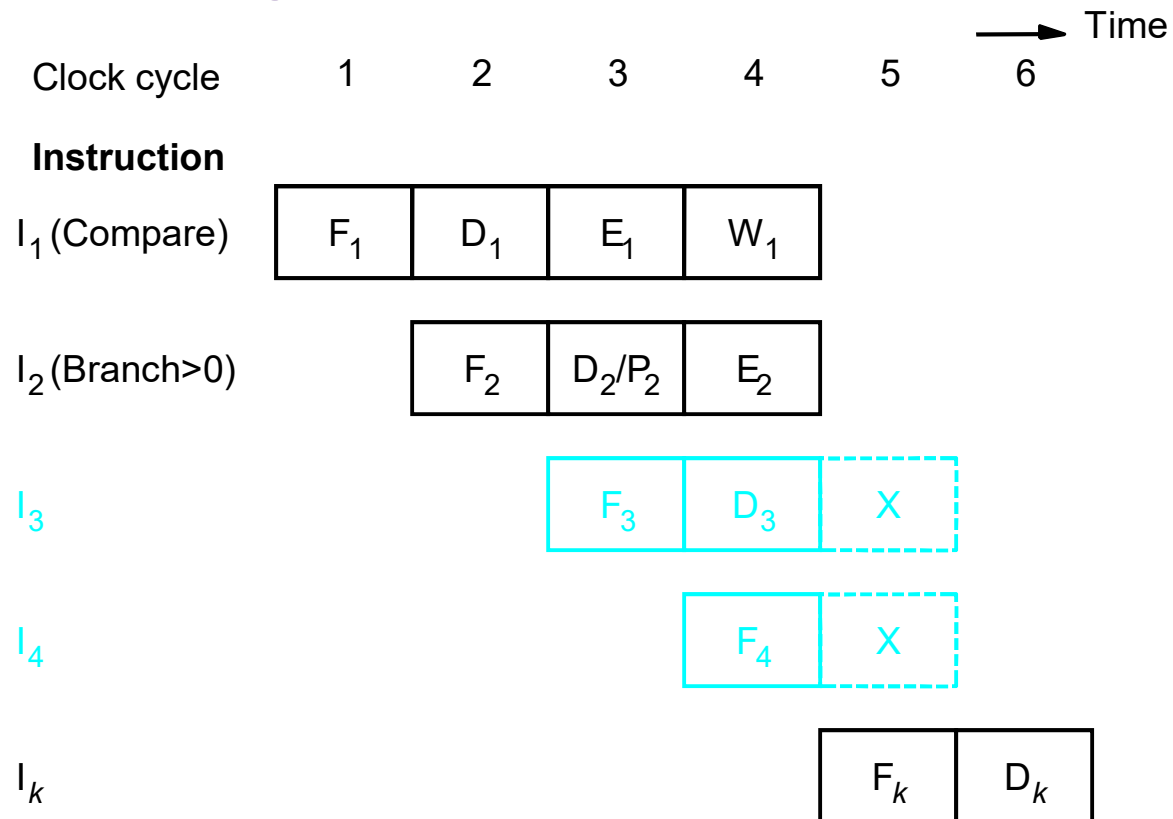
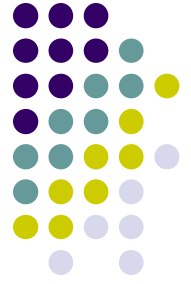

Figure 8.14. Timing when a branch decision has been incorrectly predicted as not taken.



Branch Prediction

- Better performance can be achieved if we arrange for some branch instructions to be predicted as taken and others as not taken.
- Use hardware to observe whether the target address is lower or higher than that of the branch instruction.
- Let compiler include a branch prediction bit.
- So far the branch prediction decision is always the same every time a given instruction is executed – static branch prediction.

Influence on Instruction Sets

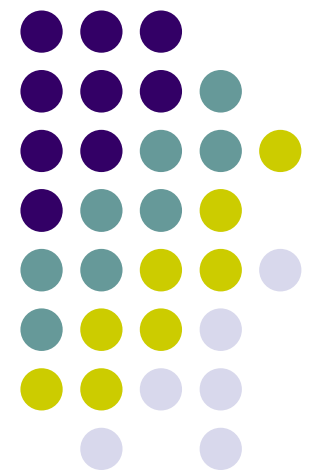

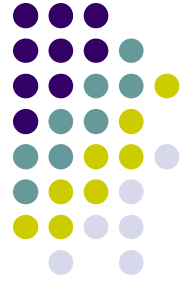

Overview

- Some instructions are much better suited to pipeline execution than others.
- Addressing modes
- Conditional code flags

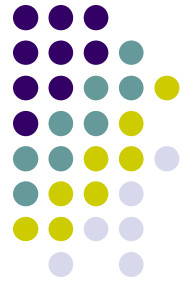

Addressing Modes

- Addressing modes include simple ones and complex ones.
- In choosing the addressing modes to be implemented in a pipelined processor, we must consider the effect of each addressing mode on instruction flow in the pipeline:
 - Side effects
 - The extent to which complex addressing modes cause the pipeline to stall
 - Whether a given mode is likely to be used by compilers

Recall

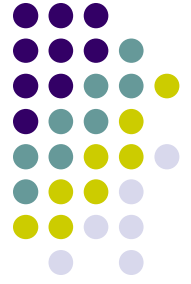

Load X(R1), R2

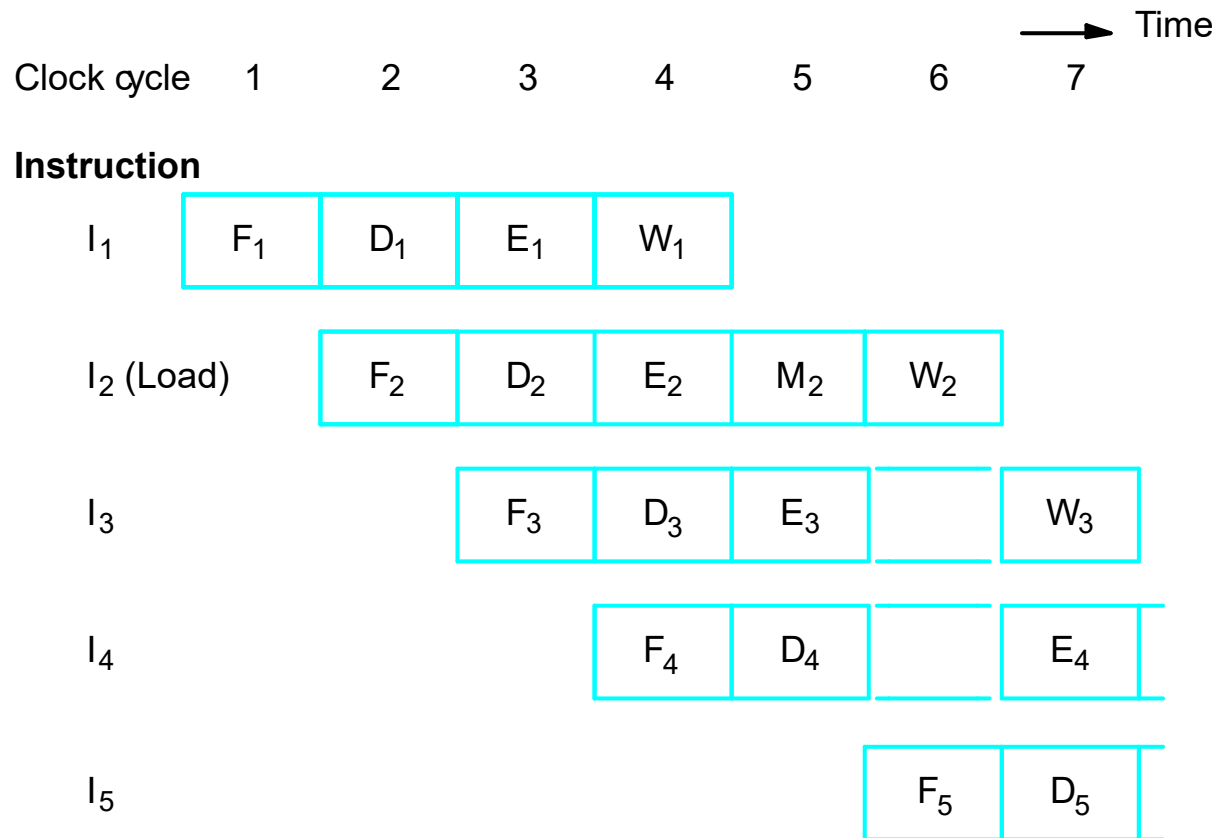

Load (R1), R2

Figure 8.5. Effect of a Load instruction on pipeline timing.

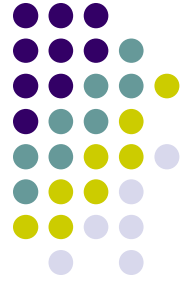

Complex Addressing Mode

Load (X(R1)), R2

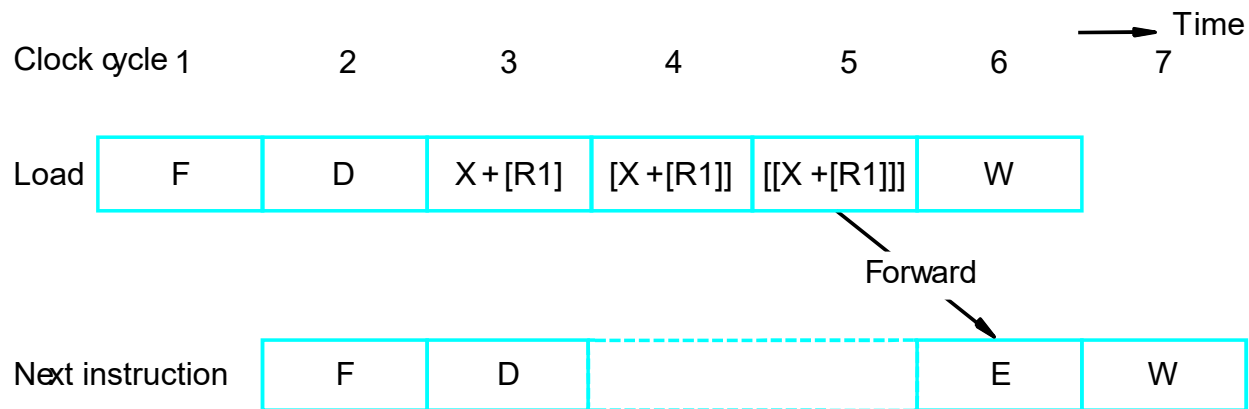

(a) Complex addressing mode

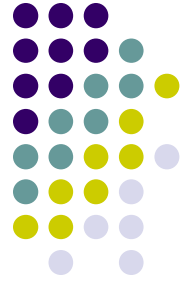

Simple Addressing Mode

Add #X, R1, R2
Load (R2), R2
Load (R2), R2

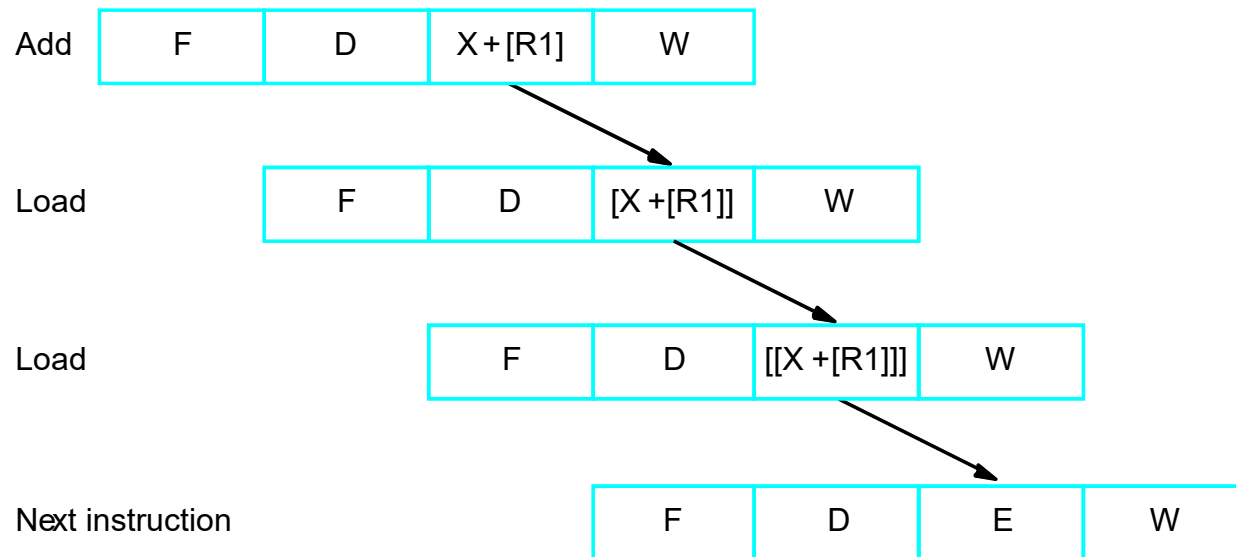

(b) Simple addressing mode

Addressing Modes



- In a pipelined processor, complex addressing modes do not necessarily lead to faster execution.
- Advantage: reducing the number of instructions / program space
- Disadvantage: cause pipeline to stall / more hardware to decode / not convenient for compiler to work with
- Conclusion: complex addressing modes are not suitable for pipelined execution.

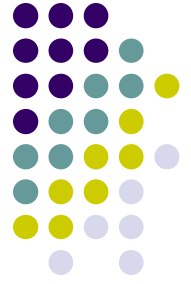

Addressing Modes

- Good addressing modes should have:
 - Access to an operand does not require more than one access to the memory
 - Only load and store instruction access memory operands
 - The addressing modes used do not have side effects
- Register, register indirect, index



Conditional Codes

- If an optimizing compiler attempts to reorder instructions to avoid stalling the pipeline when branches or data dependencies between successive instructions occur, it must ensure that reordering does not cause a change in the outcome of a computation.
- The dependency introduced by the condition-code flags reduces the flexibility available for the compiler to reorder instructions.

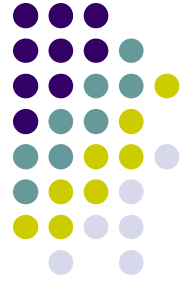

Conditional Codes

Add	R1,R2
Compare	R3,R4
Branch=0	...

(a) A program fragment

Compare	R3,R4
Add	R1,R2
Branch=0	...

(b) Instructions reordered

Figure 8.17. Instruction reordering.

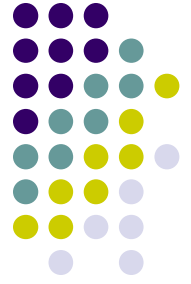

Conditional Codes

- Two conclusion:
 - To provide flexibility in reordering instructions, the condition-code flags should be affected by as few instruction as possible.
 - The compiler should be able to specify in which instructions of a program the condition codes are affected and in which they are not.

Datapath and Control Considerations

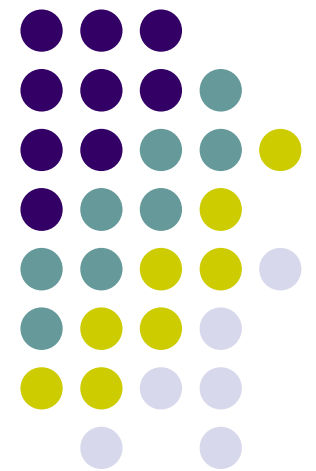

Original Design

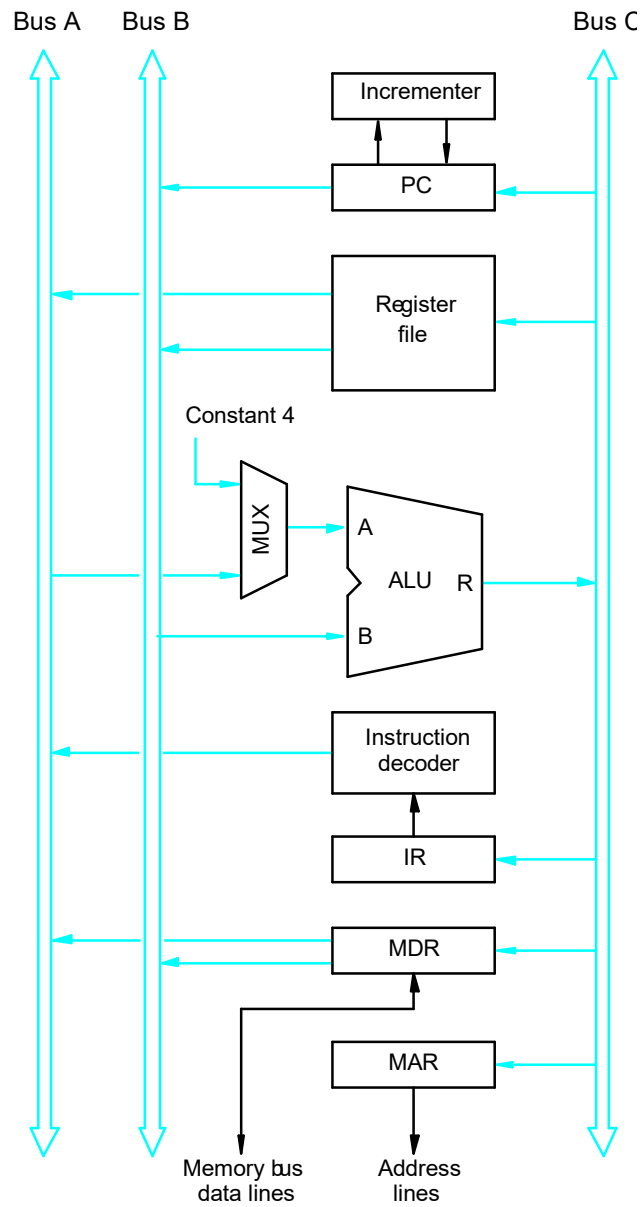
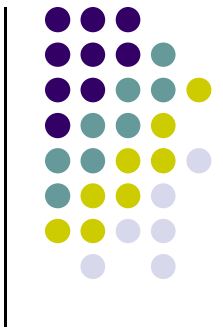
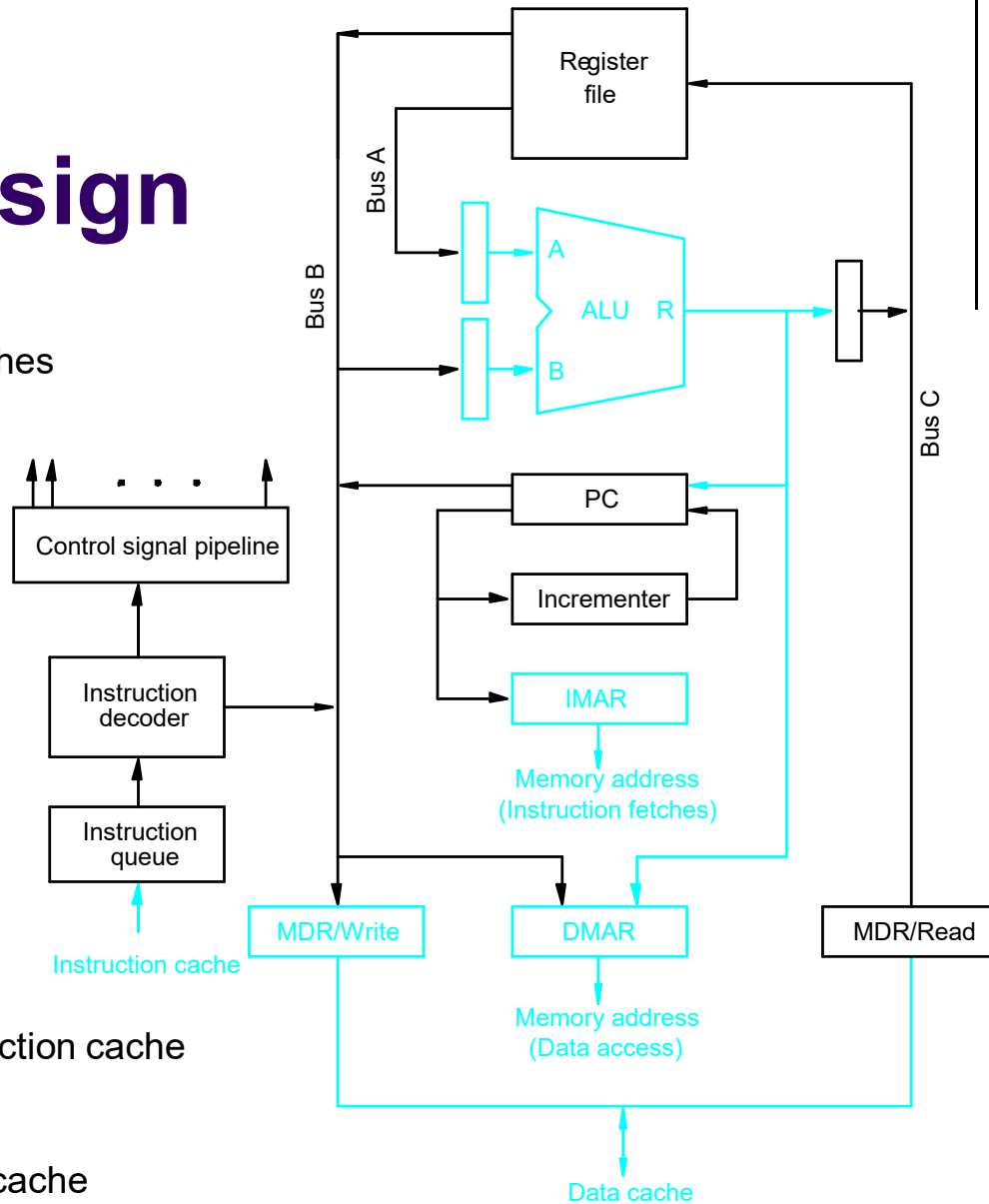

Figure 7.8. Three-bus organization of the datapath.

Pipelined Design

- Separate instruction and data caches
- PC is connected to IMAR
- DMAR
- Separate MDR
- Buffers for ALU
- Instruction queue
- Instruction decoder output



- Reading an instruction from the instruction cache
- Incrementing the PC
- Decoding an instruction
- Reading from or writing into the data cache
- Reading the contents of up to two regs
- Writing into one register in the reg file
- Performing an ALU operation

Figure 8.18. Datapath modified for pipelined execution, with interstage buffers at the input and output of the ALU.

Superscalar Operation

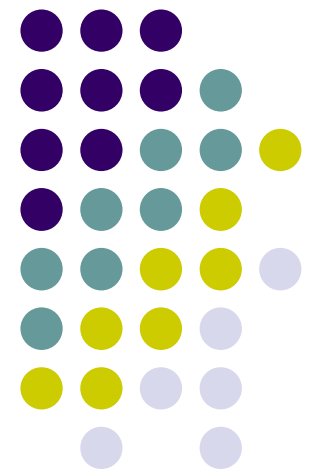

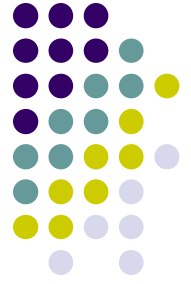

Overview

- The maximum throughput of a pipelined processor is one instruction per clock cycle.
- If we equip the processor with multiple processing units to handle several instructions in parallel in each processing stage, several instructions start execution in the same clock cycle – multiple-issue.
- Processors are capable of achieving an instruction execution throughput of more than one instruction per cycle – superscalar processors.
- Multiple-issue requires a wider path to the cache and multiple execution units.

Superscalar

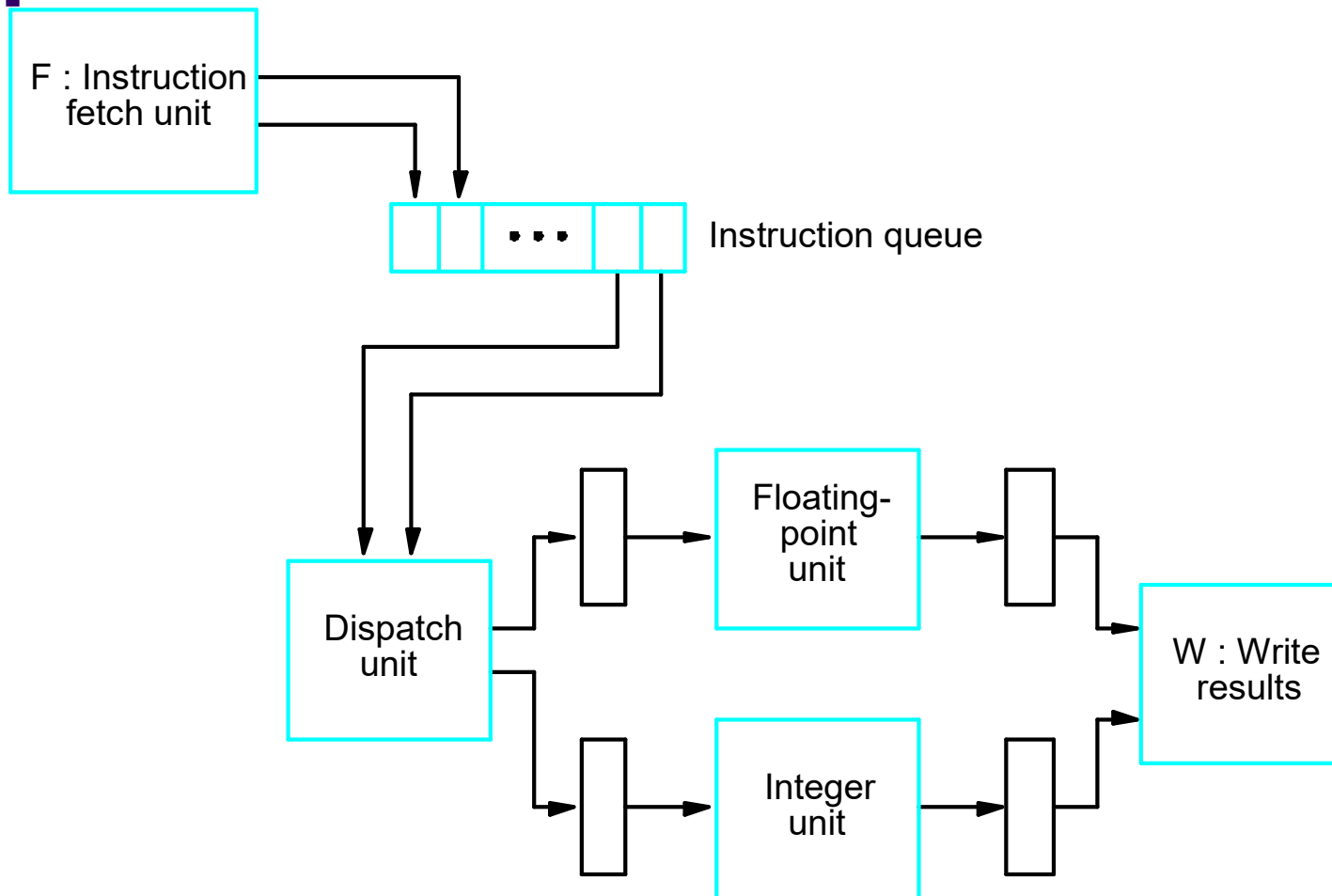
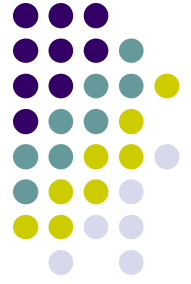

Figure 8.19. A processor with two execution units.

Timing

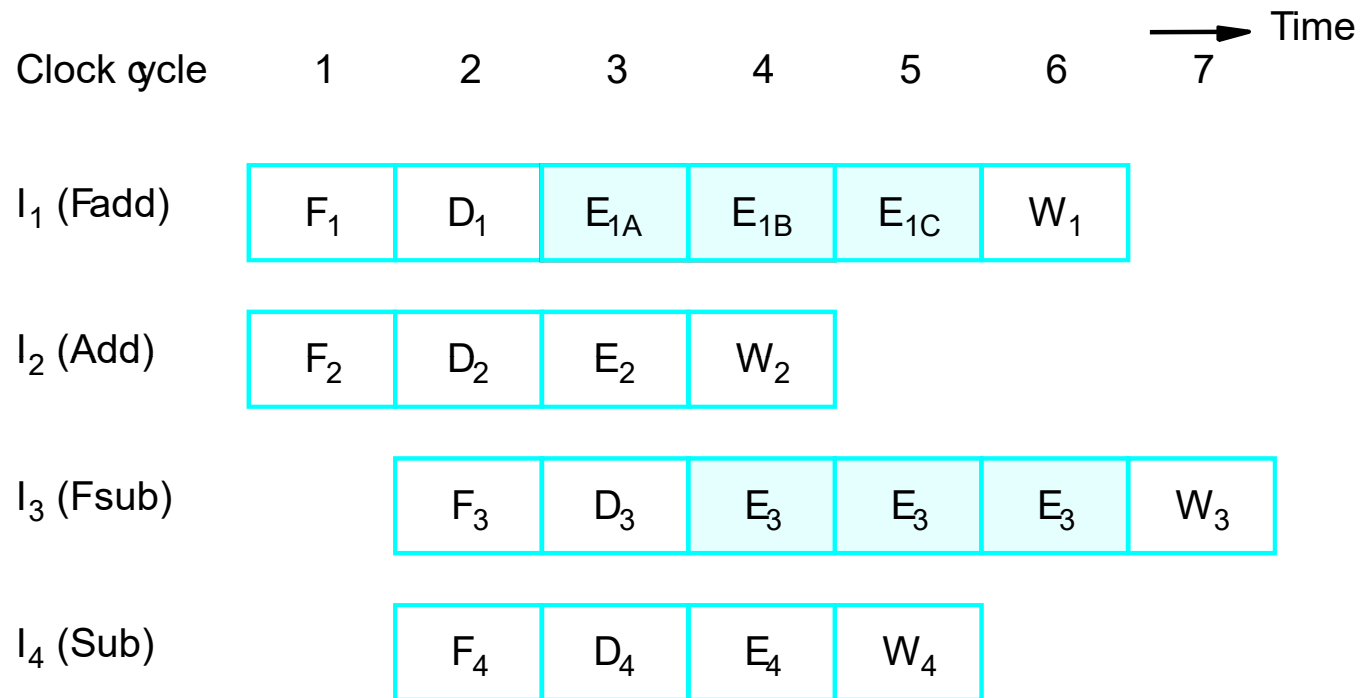
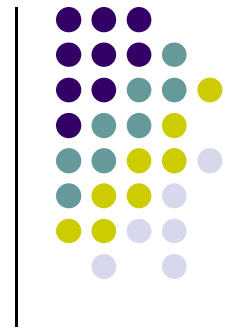
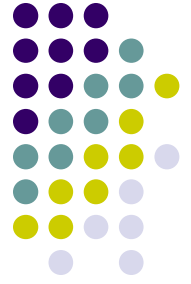
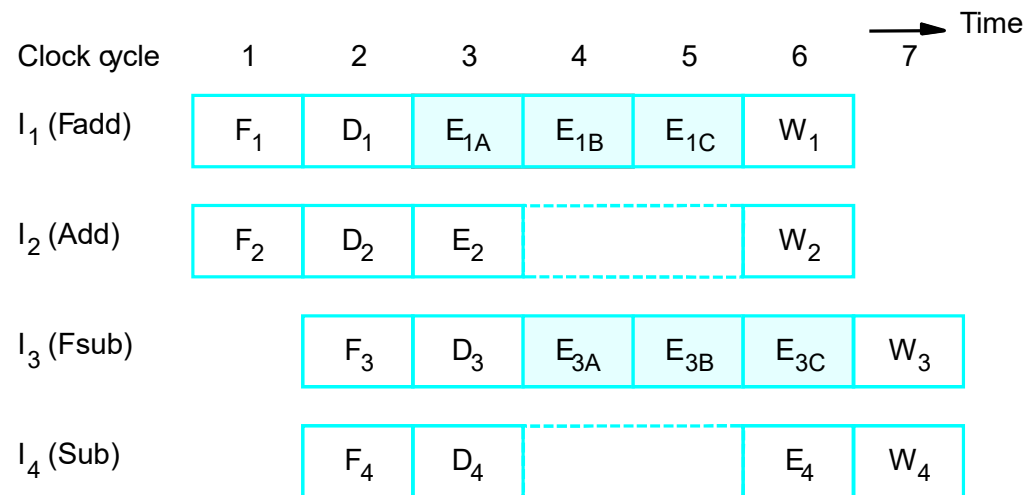

Figure 8.20. An example of instruction execution flow in the processor of Figure 8.19, assuming no hazards are encountered.



Out-of-Order Execution

- Hazards
- Exceptions
- Imprecise exceptions
- Precise exceptions



(a) Delayed write

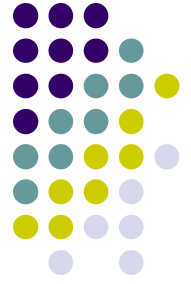

Execution Completion

- It is desirable to use out-of-order execution, so that an execution unit is freed to execute other instructions as soon as possible.
- At the same time, instructions must be completed in program order to allow precise exceptions.
- The use of temporary registers
- Commitment unit

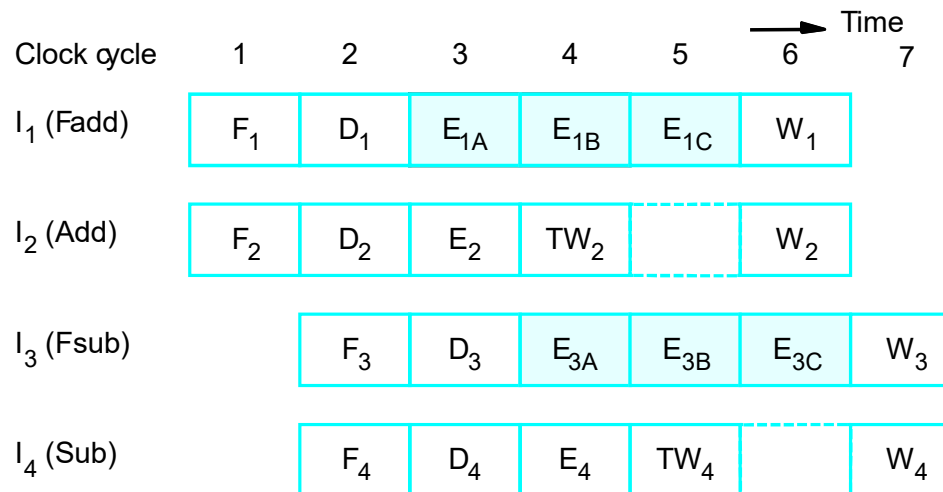

(b) Using temporary registers

Performance Considerations

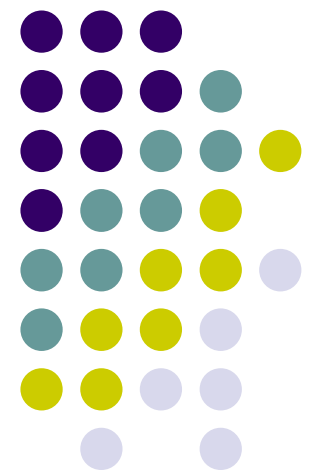

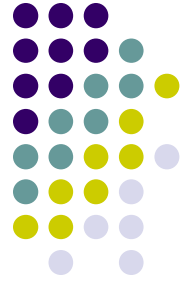

Overview

- The execution time T of a program that has a dynamic instruction count N is given by:

$$T = \frac{N \times S}{R}$$

where S is the average number of clock cycles it takes to fetch and execute one instruction, and R is the clock rate.

- Instruction throughput is defined as the number of instructions executed per second.

$$P_s = \frac{R}{S}$$

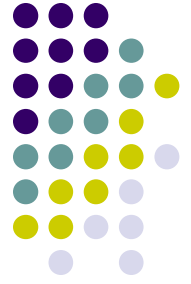

Overview

- An n -stage pipeline has the potential to increase the throughput by n times.
- However, the only real measure of performance is the total execution time of a program.
- Higher instruction throughput will not necessarily lead to higher performance.
- Two questions regarding pipelining
 - How much of this potential increase in instruction throughput can be realized in practice?
 - What is good value of n ?

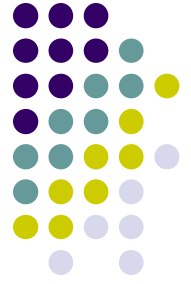

Number of Pipeline Stages

- Since an n -stage pipeline has the potential to increase the throughput by n times, how about we use a 10,000-stage pipeline?
- As the number of stages increase, the probability of the pipeline being stalled increases.
- The inherent delay in the basic operations increases.
- Hardware considerations (area, power, complexity,...)